

NOTE: TO HANG A 96" LONG UNIT PLEASE ALSO USE L-HANGERS PER THE MOUNTING INSTRUCTIONS ENCLOSED IN BAGGED MOUNTING HARDWARE.

1. RECOMMENDED HEIGHT OF UNIT IS 78" FROM TOP OF UNIT TO FLOOR. MARK TOP HOLE LEVEL 76-7/16" FROM FLOOR. USING A LEVEL TO ENSURE THAT UNIT IS HORIZONTAL MARK HOLE LOCATIONS PER FOLLOWING CHART (FIG. 1):

NOMINAL UNIT WIDTH	18"	24"	30"	36"	48"	60"	72"	96"
DISTANCE BETWEEN MOUNTING HOLE CENTERS	14-13/16"	20-13/16"	26-13/16"	32-13/16"	43-15/16"	55-15/16"	67-1/16"	92-13/16"

2. TO MOUNT ON PLASTERBOARD WALLS...
 DRILL 3/8" DIA. HOLES AS MARKED.
 INSERT ANCHOR INTO WALL, ALLOWING THE SCREW HEAD TO PROTRUDE 1/4" MAX FROM WALL (FIG. 2). HANG UNIT ONTO PROTRUDING SCREW HEADS USING SHEET METAL BRACKETS ON REAR OF UNIT (FIG. 3).

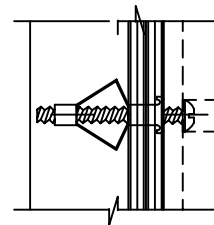

FIG. 2

MOUNTING HARDWARE (NOT INCLUDED)



HOLLOW WALL ANCHOR
 #10-24 X 2-1/16"

-- MAY BE ACQUIRED FROM LOCAL SOURCE --

MESSAGE CENTER INSTRUCTION SHEET

GHENT
 MANUFACTURING INC
 ISMCT9709

Series PA & PB

ENCLOSED BULLETIN, LETTER, & TACK BOARDS

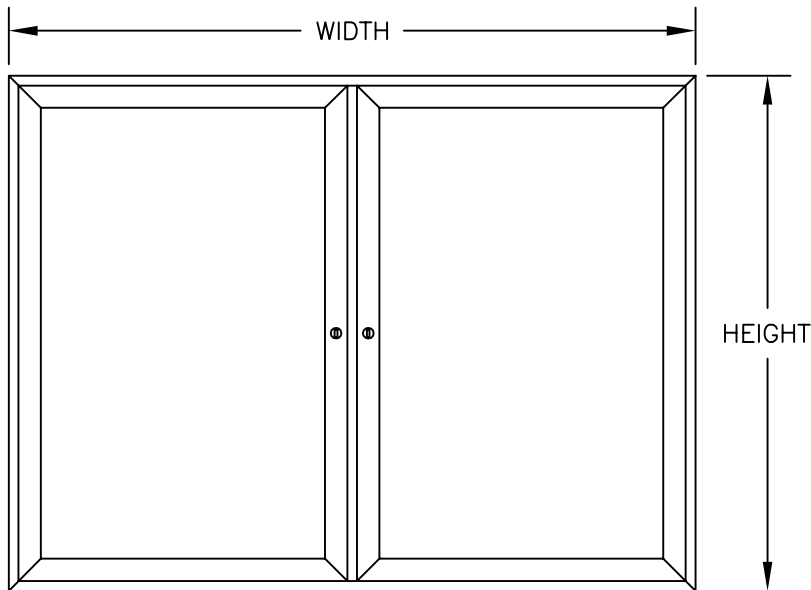

Also available in one and three door models.

3/8" THK. FOR CORK & TACK BOARDS
1/2" THK. FOR LETTERPANELS
REF.

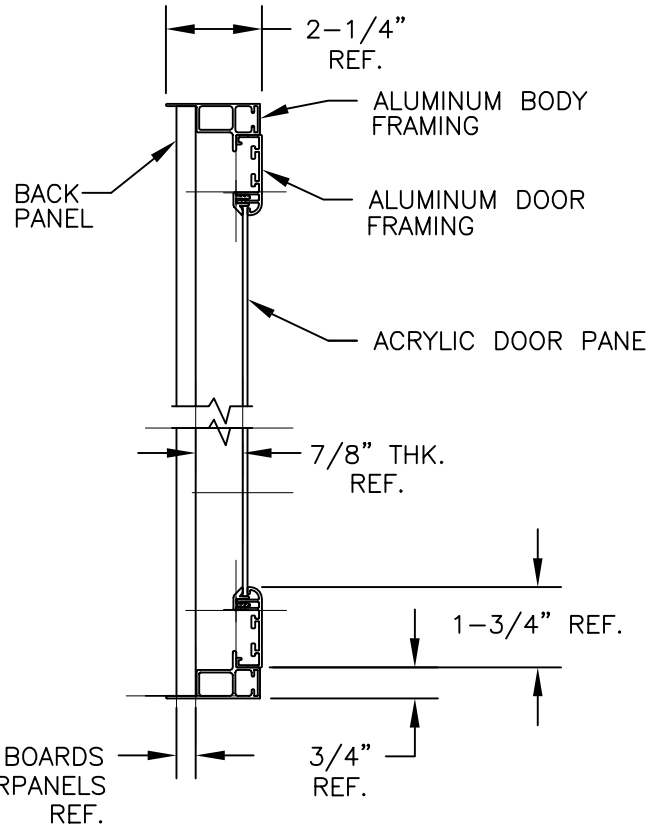

Specifications:

All exposed metal is to be satin (PA) or bronze (PB) anodized extruded aluminum 6063-T5. Body frame and doors are constructed with mitered corners. Doors have 1/8" thick acrylic panes, continuous hinges and tumble locks with keys. Door frames are self supporting and do not depend on the acrylic panes for strength. The interior panel of the unit can be one of the following: fabric or cork tack board, felt changeable letter panels (for interior use), or vinyl changeable letter panels (for exterior use). Panels for exterior units have foil backing and silicone caulking. Sizes range from 24"H X 18"W to 48"H X 96"W.

Inside Dimensions:

Overall Width minus 1 3/8" x Overall Height minus 1 3/8" x 7/8" Deep

Series PAK and PAB

DIRECTORIES AND ENCLOSED BULLETIN BOARDS WITH MODULAR HEADER

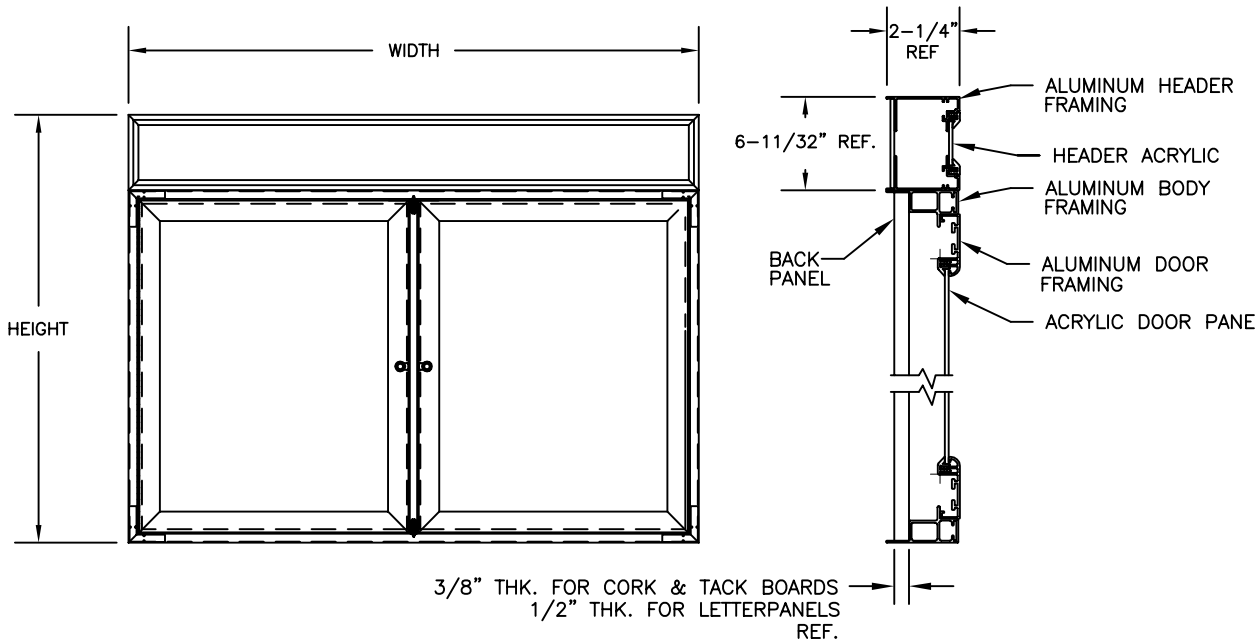

Specifications

All exposed metal shall be anodized extruded 6063-T5 alloy aluminum. Body shall be assembled with hairline mitered corners. Doors and header shall have 1/8" thick acrylic panes. Doors to be equipped with continuous piano hinge and built-in lock with keys. Door frames are self-supporting and shall not depend on the acrylic panes for strength. The back panel of the case shall be fitted with optional vinyl or cork tackboard panels, felt changeable letter panels for interior use or vinyl changeable letter panels for exterior use. Back panels for exterior units shall have foil backing and silicone caulking. Exterior units are water resistant, not waterproof.

Available sizes:

1-door units:	36Hx24W	36Hx30W	36Hx36W
2-door units:	36Hx48W	36Hx60W	48Hx60W
3-door units:	36Hx72W	48Hx72W	48Hx96W

Inside Dimensions:

Overall Width minus 1 3/8" x Overall Height minus 7 23/32" x 7/8" Deep

Series PAKL and PABL

DIRECTORIES AND ENCLOSED BULLETIN BOARDS WITH LIGHTED
MODULAR HEADER

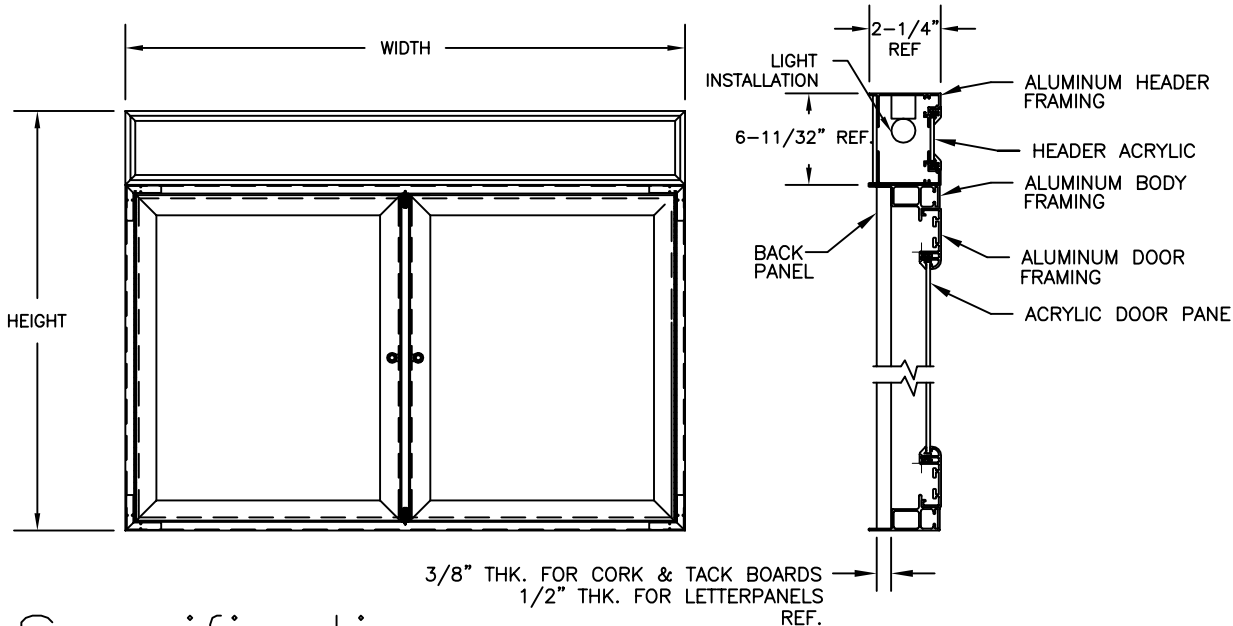

Specifications

All exposed metal shall be anodized extruded 6063-T5 alloy aluminum. Body shall be assembled with hairline mitered corners. Doors and header shall have 1/8" thick acrylic panes. Doors to be equipped with continuous piano hinge and built-in lock with keys. Door frames are self-supporting and shall not depend on the acrylic panes for strength. The back panel of the case shall be fitted with optional vinyl or cork tackboard panels, felt changeable letter panels for interior use or vinyl changeable letter panels for exterior use. Body back panels for exterior units shall have foil backing and silicone caulking. Header back panels for exterior units shall have mylar backing and weatherstrip tape underneath the panel to block moisture. Exterior units are water resistant, not waterproof. Headers come with light fixture(s) mounted, but not wired. Light(s) are to be wired by a qualified electrician.

Available Sizes:

1-door units:	36Hx24W	36Hx30W	
2-door units:	36Hx48W	36Hx60W	
3-door units:	36Hx72W	48Hx72W	48Hx96W

Inside Dimensions:

Overall Width minus 1 3/8" x Overall Height minus 7 23/32" x 7/8"
Deep