

Model No. NEX203ME



MOBILE

INTERACTIVE

VERSATILE

**Move and Collaborate –**

the Nexus Easel is a mobile, double-sided markerboard display stand that provides a flexible 4' x 3' writing area plus expandable work space for Tablets.



**nexus**<sup>™</sup>  
by Ghent

simplifying small group communication



<b>Mobile</b>	<b>Interactive</b>	<b>Versatile</b>
Simple to move from room to room for use where you need it	Flexible and expandable presentation areas with side-mountable Tablet markerboards (sold separately)	Provides a large and interactive display space for group presentations

**Key Features**

- Double-sided, 4'x3' magnetic marker surface – more durable, reusable and greener solution than traditional chart pads
- Angled foot design – allows units to be grouped for a more coordinated collaboration space
- Expandable workspace – attachable easel pegs give you the option of adding Tablets for additional room
- In reach – comes complete with side-mountable marker/eraser holder
- Backed by a Ghent 10-year guarantee

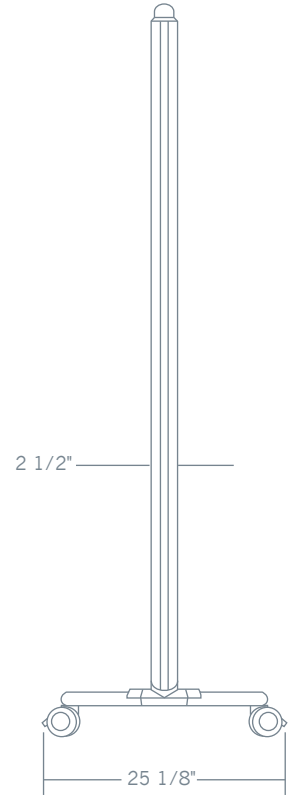
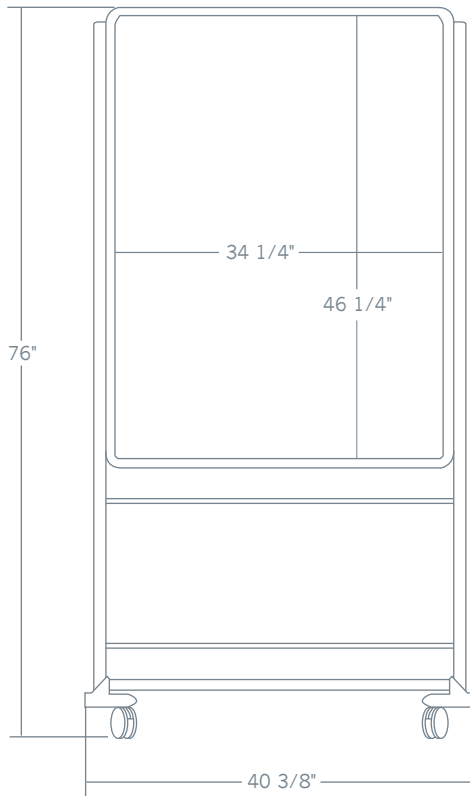
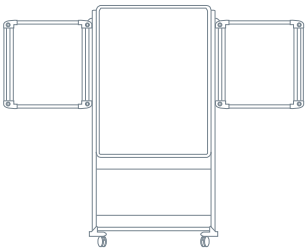

Find out more  
[NexusByGhent.com](http://NexusByGhent.com)

Specifications		Model No.
Dimensions	76" (193 cm) x 40-3/8" (102.6 cm) x 25-1/8" (63.8 cm)	NE203ME
Weight	52 lbs	

**Accent Panel Colors**



**GHENT**

Ghent Manufacturing, Inc.  
 2999 Henkle Drive  
 Lebanon, Ohio 45036  
 T 800-543-0550  
 P 513-932-3445  
 F 513-932-9252  
[ghent.com](http://ghent.com)

