



Model Nos. **NEX016XHS**
NEX026XHL



VERSATILE

PRACTICAL

INTERACTIVE

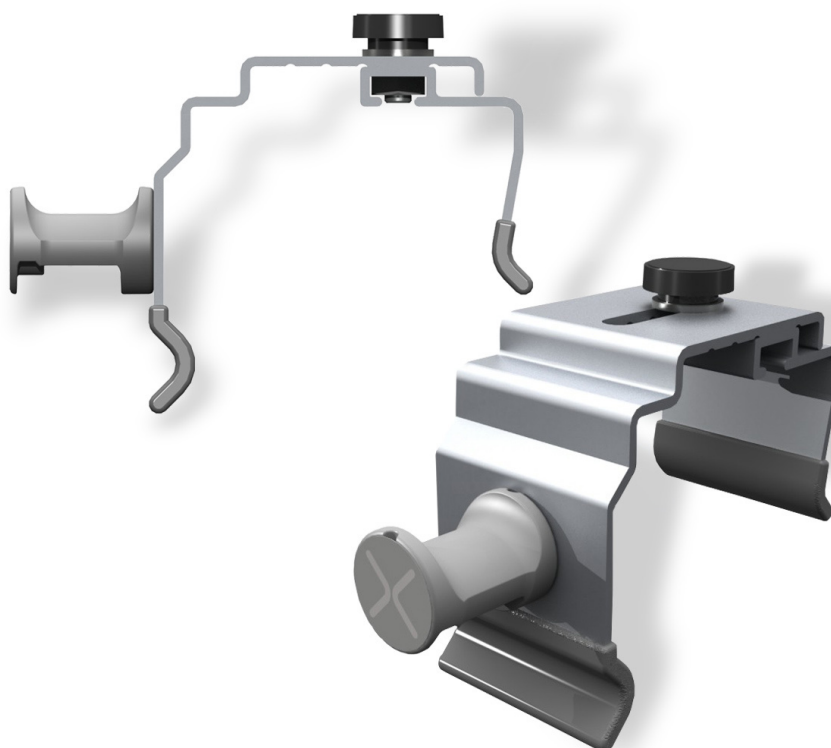

Integrate and Engage –

The Nexus X-Hangers are an adjustable display system for Tablet markerboards that becomes the starting point for plans and ideas in open design environments.



nexus[®]
by Ghent

simplifying small group communication



Versatile

Adjustable design offered in two different sizes fits divider panels from 1-1/2" to 2-1/2" thick and 2-1/2" to 3-1/2" thick

Practical

Allows the Nexus Tablet to hang securely in place simply and easily

Interactive

Brings the effectiveness of a Tablet markerboard inside the personal workspace

Key Features

- Panel hangers adjust to fit snugly onto various thicknesses of dividers, panel systems or cubical walls
- Simple to use – Tablet corner designed with X-Hanger sized opening for intuitive connection and fit
- Easy to hang – Attaches onto top of partition with thumb screw to secure into position
- Protective vinyl-coated edges to prevent marring and scratching
- Backed by a Ghent 1-year guarantee

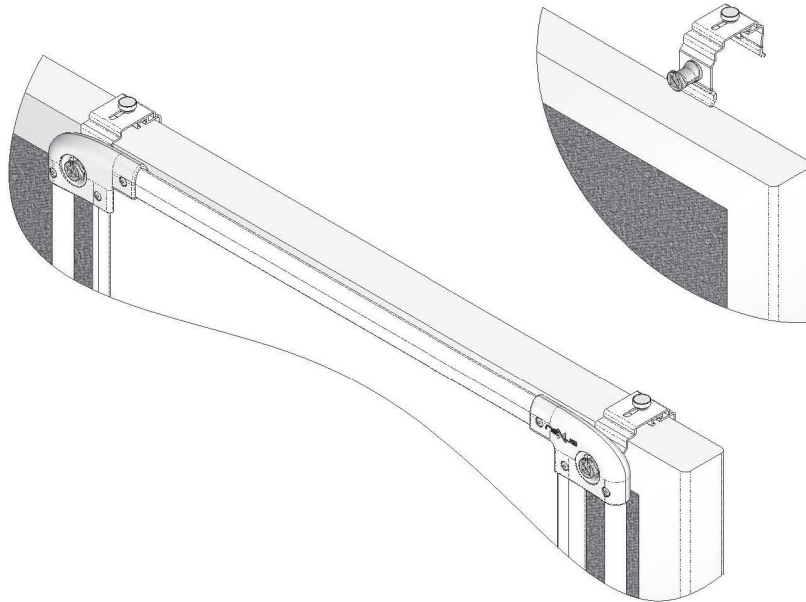
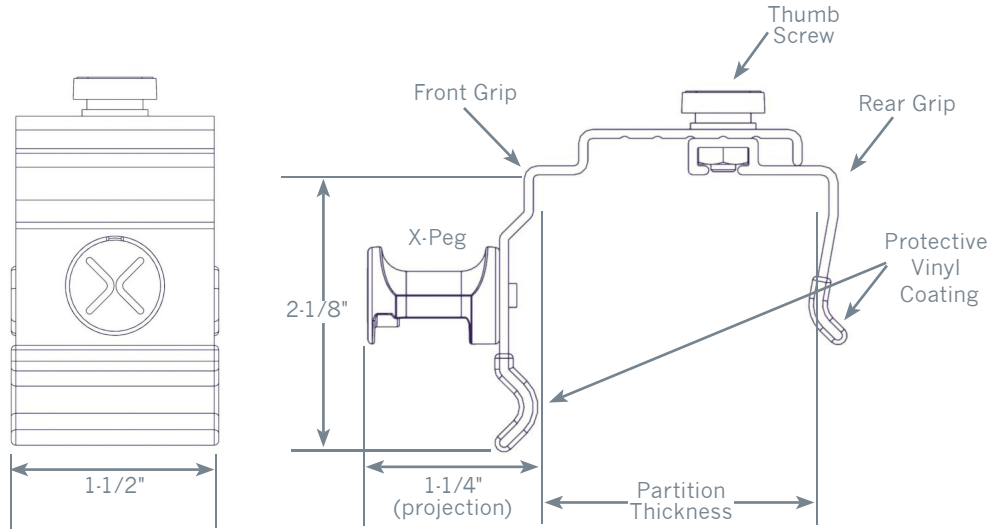

Find out more
NexusByGhent.com

GHENT
 Ghent Manufacturing, Inc.
 2999 Henkle Drive
 Lebanon, Ohio 45036
 T 800-543-0550
 P 513-932-3445
 F 513-932-9252
ghent.com

Specifications		Model Nos.
Width	1-1/2" (3.81 cm)	NEX016XHS NEX026XHL
Projection Depth	1-1/4" (3.175 cm)	

NEX016XHS - fits partitions 1-1/2" - 2-1/2" thick
NEX026XHL - fits partitions 2-1/2" - 3-1/2" thick

